

**CIMEX**

**R48/HD Handle Assembly**

Drawing Number: 09-1047-0000

Date:	2/4/2009		
Machine:	R48/HD		
Reference Parts List:	05-4496-0000		
Modified By:	G SECHERE	DESCRIPTION OF CHANGE	ECN #
Revision:	B	COMPONENTS CHANGE	N/A



## R48/HD Handle Assembly

Part Reference: 05-4496-0000

Date:	2/4/2009		
Machine:	R48/HD		
Reference Drawing Number:	09-1047-0000		
Modified By:	G SECHERE	DESCRIPTION OF CHANGE	ECN #
Revision:	B	COMPONENTS CHANGE	N/A

Ref. No.	Part No.	Part Description	Qty
<b>CORE COMPONENTS</b>			
1	02-3950-0000	3/4 in EXTERNAL CIRCLIP	1
2	02-4065-0000	SLEEVING 2MM CLEAR	4"
3	02-4175-0000	HANDLE GRIP	2
4	02-4176-0000	GROMMET	1
5	02-4186-0000	CABLE GLAND	1
6	02-4311-0000	PENNY WASHER	1
7	02-4149-0000	TYRAP - SMALL (BI) *NOT SOWHN*	7
8	02-3702-0000	SLEEVING FOR CABLE (10/13AMP) *NOT SHOWN*	40"
10	03-6185-0000	EARTH POINT LABEL	1
11	03-6953-0000	LOCKING HANDLE	1
13	03-6957-0000	PIVOT	1
14	03-7281-0000	LEVER	1
16	03-7298-0000	SWITCH CAM LEVER	1
17	03-7300-1000	HANDLE BOX (FRONT & REAR SET)	1
19	03-7433-0000	CAM FOLLOWERS	1
20	03-7434-0000	SPRING	1
21	03-7435-0000	REVERSE SWITCH CAMS	1
22	03-7660-0000	CABLE HOOK	1
23	03-8005-0000	CR / RHD COMMON HANDLE FRAME	1
29	02-4026-0000	P CLIP (DROPLEAD)	1
30	02-4219-0000	P CLIP (MAINS CABLE)	1
31	04-3416-0000	SUPPRESSOR RF 0.47UF	1
33	04-3576-0000	CRIMP TERMINAL PRE-INSULATED *NOT SHOWN*	5
32	04-3480-0000	TERMINAL (FORK) *NOT SHOWN*	2
34	04-3481-0000	TERMINAL (SPRING SPADE) *NOT SHOWN*	4
35	04-3602-0000	TERMINAL (RING) *NOT SHOWN*	2
36	04-3681-0000	MAINS CABLE 1.5MM SQ GREY PVC 3 CORE	600"
37	04-3686-0000	SWITCH (MOMENTARY)	1
38	04-3809-0000	SWITCH (CAM OPERATED)	1
43	04-3553-0000	CABLE 2.5MM 14AWG BLACK *NOT SHOWN* (DROPLEAD)	158"
44	04-3556-0000	CABLE 2.5MM 14AWG BLUE *NOT SHOWN* (DROPLEAD)	79"
45	04-3558-0000	CABLE 2.5MM 14AWG BROWN *NOT SHOWN* (DROPLEAD)	79"
46	04-3559-0000	CABLE 2.5MM 14AWG GREEN/YELLOW *NOT SHOWN* (DROPLEAD)	79"
47	04-3552-0000	CABLE 2.5MM 14AWG RED *NOT SHOWN* (DROPLEAD)	79"
48	04-0299-0000	PLUG (UK) *NOT SHOWN*	1
<b>FASTENERS</b>			
50	00-0500-0503	M5 PLAIN WASHER	4
51	00-0500-0723	M5 NYLOC NUT	2
52	00-0510-0171	M5 x 10 SOCKET SET SCREW	1
53	00-0512-0013	M5 X 12 POZI PAN HEAD SCREW	6
54	00-0540-0013	SCREW, M5 X 40 PAN HEAD	1
55	00-1000-0703	M10 FULL NUT	1
56	00-0400-0523	M4 SHAKEPROOF WASHER	2
57	00-0410-0023	M410 POZI PAN HEAD	2
58	00-0400-0703	M4 FULL NUT	2
59	00-0308-0013	M3x8 POZI PAN HD SCREW	1
61	00-0300-0503	M3 PLAIN WASHER	1
62	00-0500-0507	M5 BRASS WASHER	3
63	00-0500-0703	M5 FULL NUT	2
64	00-0500-0713	M5 LOCK NUT	1
65	00-0500-0521	M5 SHAKEPROOF WASHER Z/P	1
66	00-1000-0523	M10 SHAKEPROOF WASHER	1
67	00-0520-0013	M5x20 POZI PAN HD SCREW	1
68	00-0518-0013	M5 X 12 POZI PAN HEAD SCREW	1

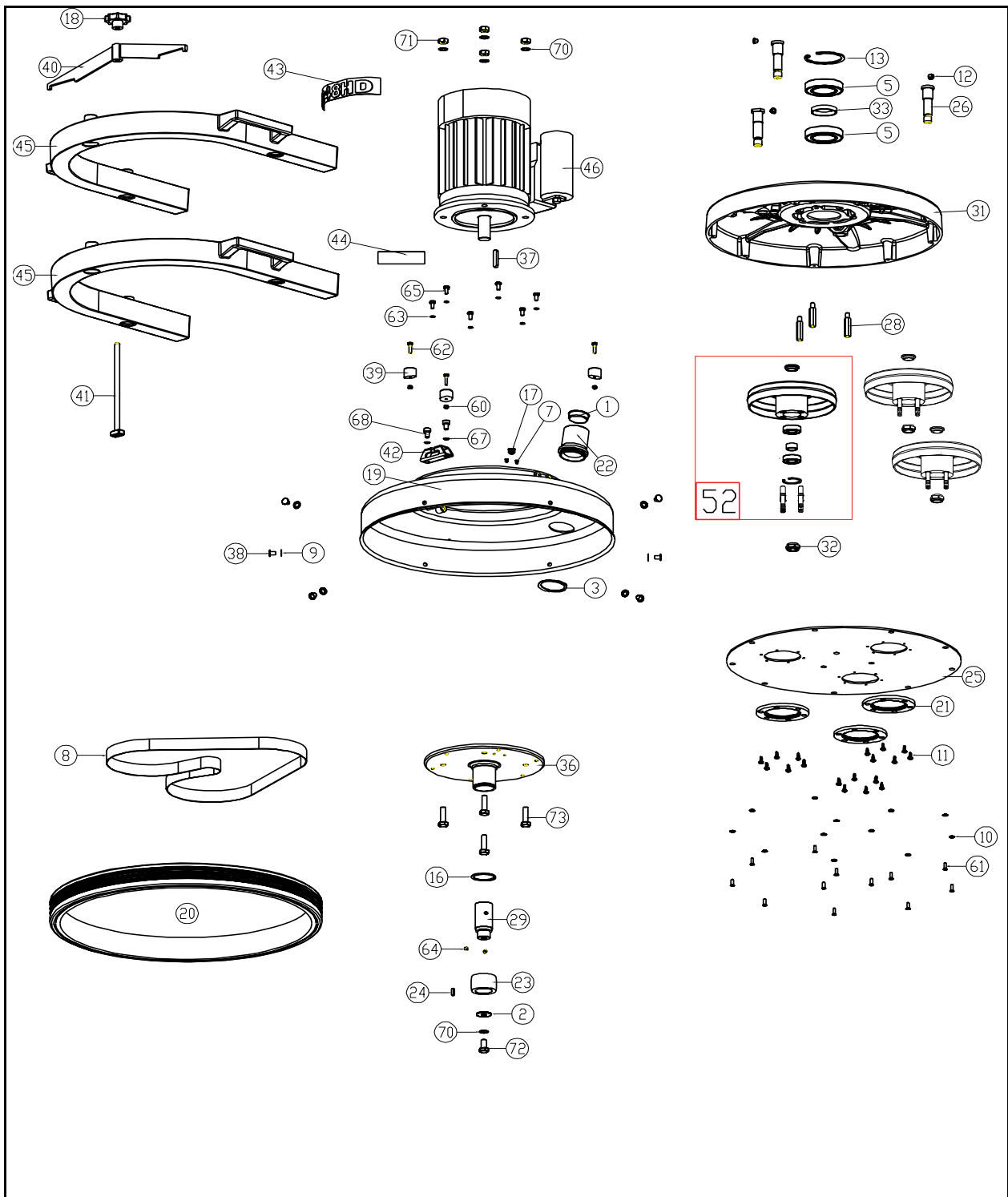

<b>CIMEX</b>		<b>R48/HD Head Assembly</b>	
Drawing Number: 09-1072-0000			
Date:	2/4/2009		
Machine:	R48/HD		
Reference Parts List:	05-3917-0000		
Modified By:	G SECHERE	DESCRIPTION OF CHANGE	ECN #
Revision:	B	COMPONENTS CHANGE	N/A

**CIMEX****R48/HD Head Assembly**

Part Reference: 05-3917-0000

Date:	2/4/2009		
Machines:	R48/HD		
Reference Drawing Number:	09-1072-0000		
Approved By:	G SECHERE	DESCRIPTION OF CHANGE	ECN #
Revision:	B	COMPONENTS CHANGE	N/A

Ref. No.	Part No.	Part Description	Qty
<b>CORE COMPONENTS</b>			
1	02-4587-0000	VAC TUBE PLUG	1
2	02-4335-0000	M10 WASHER	1
3	02-4184-0000	CIRCLIP 46.5 ID (VACUUM OUTLET)	1
4	02-4025-0000	M5 SPLINED LARGE FLANGE *NOT SHOWN*	1
5	02-4020-0000	BEARING 6009-2RS	2
7	02-4035-0000	POP RIVET (HOLE BLANKING)	2
8	02-4191-0000	BELT - NITTA 1465x25 (BLUE POLY)	1
9	02-4085-0000	STARLOCK WASHER 8mm	6
10	02-4320-0000	BRASS CUP WASHER No8	12
11	02-4323-0000	SELF TAP No10x12 POZI PAN HD ST/ST	18
12	02-4381-0000	PLASTIC INSERT (REF 12157)	3
13	02-4380-0000	CIRCLIP INTERNAL 1300 - 75mm	1
16	02-4024-0000	CIRCLIP EXTERNAL	1
17	02-4161-0000	HOLE PLUG	1
18	02-4447-0000	CLAMP KNOB	1
19	03-6972-0000	BUMPER SHIELD	1
20	03-7395-0000	BUMPER RUBBER	1
21	03-6910-0000	DUST SEAL	3
22	03-8090-0000	2" O/D VACUUM OUTLET	1
23	03-6927-0000	MOTOR PULLEY NOM DIA 50mm	1
24	03-6931-0000	KEY 3/16 x 3/16 x 5/8	1
25	03-6940-0000	BOTTOM COVER PLATE	1
26	03-7331-0000	BRUSH SPINDLE - NO WATER	3
28	03-6946-0000	BOTTOM COVER SPACER	3
29	03-6968-0000	MOTOR SHAFT EXTENSION	1
31	03-6962-0000	EDU BOWL (BLUE) CR48	1
32	03-7220-0000	M16 NYLOC NUT (M'C'D)	3
33	03-7284-0000	CENTRE BEARING SPACER	1
36	03-6971-0000	SPIGOT PLATE	1
37	03-7008-0000	SPECIAL KEYBAR	1
38	03-6967-0000	HD SKIRT PIN	6
39	03-6969-0000	WEIGHT LOCATOR	3
40	03-7714-0000	WEIGHT CLAMP BAR	1
41	03-7715-0000	WEIGHT CLAMP BOLT	1
42	03-7716-0000	WEIGHT CLAMP BRACKET	1
43	03-6806-0000	DECAL - R48 HD	1
44	03-7944-0000	DECAL - CIMEX FROM TRUVOX *NOT SHOWN*	1
45	03-7004-0000	BALLAST WEIGHT	2
46	04-3852-0000	MOTOR 230V 50Hz 1.5kW 4 POLE	1
47	04-3602-0000	TERMINAL (RING) *NOT SHOWN*	6
52	05-4546-0000	R48HD PULLEY ASSEMBLY	3
53	72470A	HEAT SHRINK TUBING	12"
<b>FASTENERS</b>			
60	00-0500-0723	M5 NYLOC NUT ST/ST	3
61	00-0512-0033	M5x12 COUNTERSUNK SCREW ST/ST	12
62	00-0520-0013	M5x20 POZI PAN HD SCREW ST/ST	3
63	00-0600-0523	M6 INT SHAKEPROOF WASHER ST/ST	6
64	00-0606-0171	M6x6 GRUB SCREW SOCKET HD	2
65	00-0612-0113	M6 x 12 HEX HD BOLT ST/ST	6
67	00-0800-0523	M8 INT SHAKEPROOF WASHER ST/ST	2
68	00-0812-0093	M8 x 12 CAP HD SCREW ST/ST	2
70	00-1000-0523	M10 INTERNAL SHAKEPROOF WASHER	5
71	00-1000-0703	M10 LOCK NUT ST/ST	4
72	00-1020-0123	M10x20 BOLT S/S	1
73	00-1035-0111	M10x35 BOLT Z/P	4

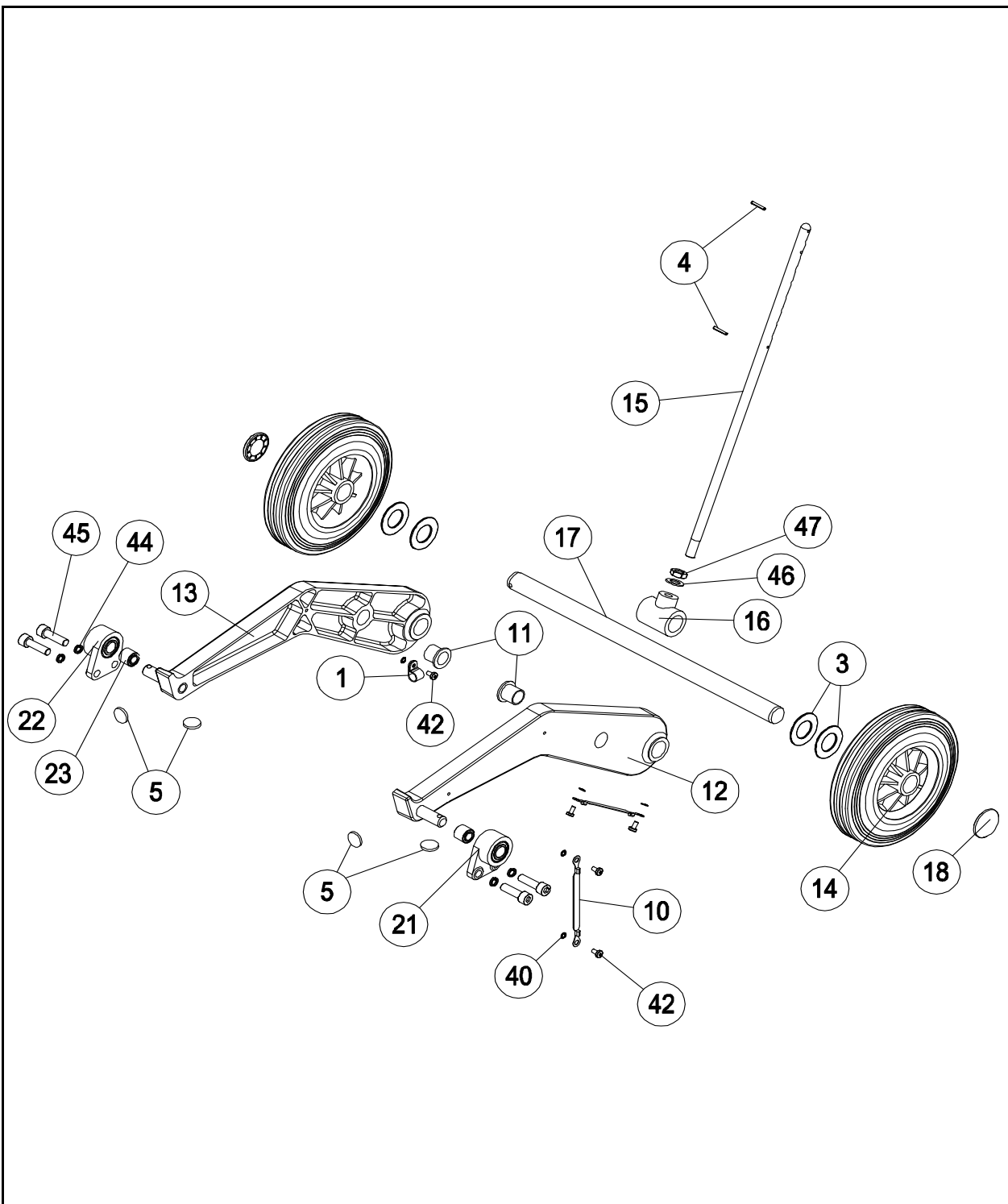

**CIMEX** **R48/HD Chassis Assembly**

Drawing Number: 09-1064-0000

Date:	2/4/2009		
Machine:	R48/HD		
Reference Parts List:	05-4479-0000		
Modified By:	G SECHERE	DESCRIPTION OF CHANGE	ECN #
Revision:	B	COMPONENTS CHANGE	N/A

**CIMEX****R48/HD Chassis Assembly****05-4479-0000**

Date:	2/4/2009		
Machine:	R48/HD		
Reference Drawing Number:	09-1064-0000		
Approved By:	G SECHERE	DESCRIPTION OF CHANGE	ECN #
Revision:	B	COMPONENTS CHANGE	N/A

Ref. No.	Part No.	Part Description	Qty
<b>CORE COMPONENTS</b>			
1	02-4448-0000	P CLIP	1
3	02-4363-0000	WASHER (USED AS WHEEL SPA CEP SUBJECT TO QTY CHANGE)	4
4	02-4208-0000	SELLOCK PIN 1/8x7/8	2
5	02-4187-0000	BUFFER RUBBER 19mm x 1.5mm	4
10	03-6899-0000	EARTH LEAD (WITH INTEGRAL TERMS)	2
11	03-6919-0000	FORK HANDLE BUSH (BLACK)	2
12	03-8175-0000	CR48 SOLID LIFTING FORK (L/H)	1
13	03-8176-0000	CR48 SOLID LIFTING FORK (R/H)	1
14	03-7277-0000	WHEEL 200mm DIA	2
15	03-7279-0000	SWIVEL CLAMP ROD	1
16	03-7306-0000	TEE PIECE	1
17	03-7308-0000	AXLE - CR48,CR61	1
18	03-7658-0000	STARLOCK HUB CAP	2
20	04-3688-0000	20mm CONDUIT *NOT SHOWN*	43"
21	03-6925-0000	PIVOT BLOCK (L/H)	1
22	03-6926-0000	PIVOT BLOCK (R/H)	1
23	03-6929-0000	SILENT BEARING	2
<b>FASTENERS</b>			
40	00-0500-0521	M5 INTERNAL SHAKEPROOF WASHER	5
42	00-0512-0013	M5x12 POZI PAN HEAD SCREW ST/ST	5
44	7CL003	M10 SPRING WASHER ST/ST	4
45	00-1030-0103	M10x30 CAP HD SCREW ST/ST	4
46	00-1200-0503	MI 2 WASHER FORM B ST/ST	1
47	00-1200-0713	M12 LOCKNUT ST/ST	1

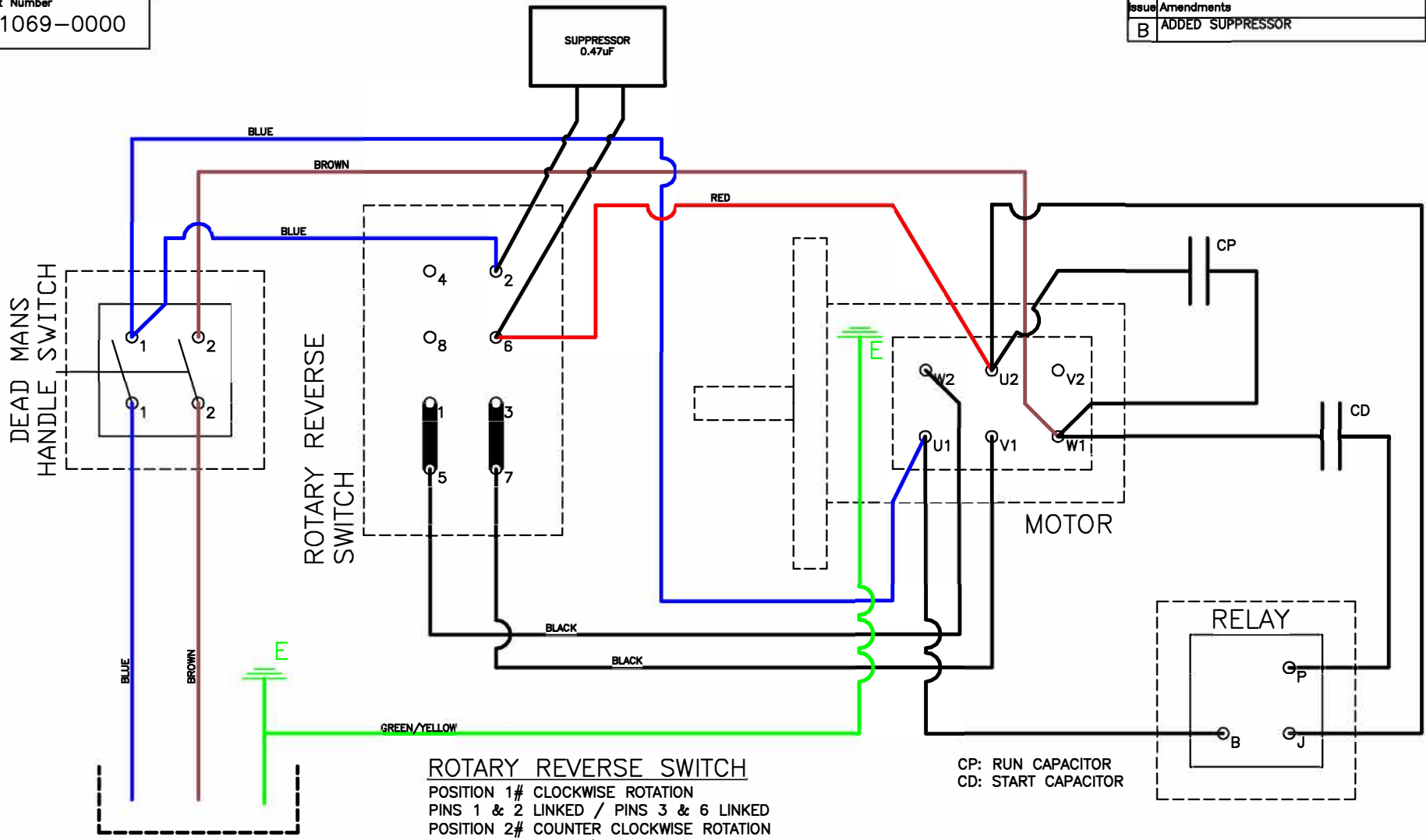

**ROTARY REVERSE SWITCH**  
 POSITION 1# CLOCKWISE ROTATION  
 PINS 1 & 2 LINKED / PINS 3 & 6 LINKED  
 POSITION 2# COUNTER CLOCKWISE ROTATION  
 PINS 2 & 3 LINKED / PINS 1 & 6 LINKED

CP: RUN CAPACITOR  
 CD: START CAPACITOR

FOR USE ON THE FOLLOWING MACHINES:-

- |                 |              |                |
|-----------------|--------------|----------------|
| CR48/DF         | CR48/DF/EURO | CG48           |
| CR76            | CR48/DF/RCD  | CG48/110       |
| CR76/EURO       | R48/HD       | CG48/110/50-60 |
| R48/HD/220      | R48/HD/EURO  | CG48/EURO      |
| R48/HD/R/230/50 | RHD76        | CG48/EURO/60   |
| RHD76/EURO      | RHD76/110/50 | R48/HD/110/50  |

3 CORE MAINS CABLE



3RD ANGLE PROJECTION  
 DIMENSIONS IN MILLIMETRES  
 DO NOT SCALE DRAWING  
 ©COPYRIGHT

Material	-----
Finish	-----
Drawn	S JONES
Checked	G.SECHERE

General Tolerance	±0.25
Scale	N.T.S.
Date	02.04.09

**CIMEX** *Get the Advantage™*  
 Title  
 (CIMEX) WIRING DIAGRAM WITH  
 LEROY SOMER MOTOR

Drawing/Part Number	09-1069-0000
---------------------	--------------

RED ON MASTER